

## MITRE CUT (H): PARALLEL FLANGE CHANNELS (TOES UP)

Customer: .....

Order number: .....

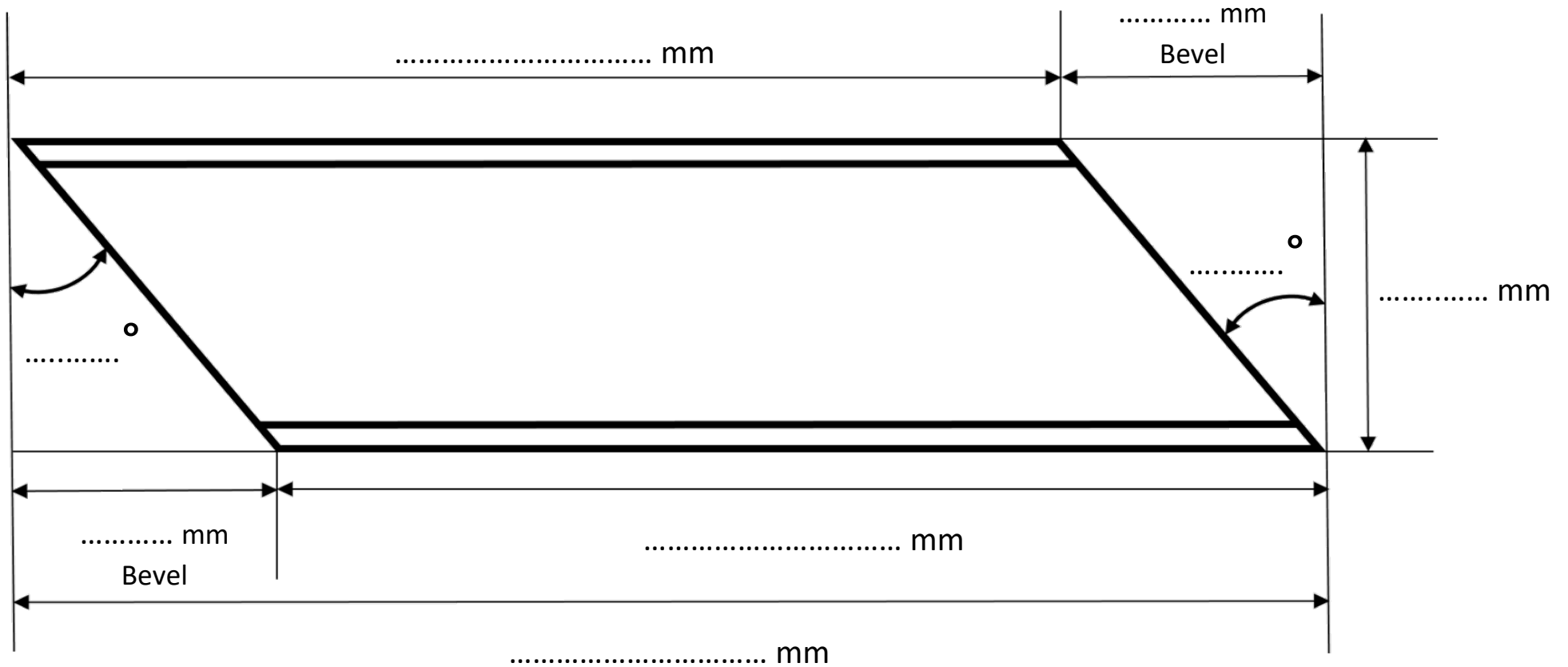

Section size: .....

Quantity: .....

Bar mark: .....

**PLEASE NOTE: SECTION WIDTH MUST BE PROVIDED BASED ON ACTUAL WIDTH, NOT THEORETICAL WIDTH**